

STANDARD EXECUTIONS

- **GN 722.2-A:** protruding plunger with the lever perpendicular to the axis of the fixing holes.
- **GN 722.2-B:** protruding plunger with the lever parallel to the axis of the fixing holes.

Index for material and finish:

- **A4:** body and lever made out of cast AISI 316 stainless steel for welding, AISI 316 stainless steel plunger, AISI 316Ti stainless steel spring.
- **SW:** body made out of cast zinc-plated steel, epoxy resin coating, RAL 9005 black colour, matte finish. Cast zinc-plated steel lever, zinc-plated steel plunger, AISI 301 stainless steel spring.
- **ZB:** body made out of cast zinc-plated steel, cast zinc-plated steel lever, zinc-plated steel plunger, AISI 301 stainless steel spring.

FEATURES AND APPLICATIONS

GN 722.2 lever indexing plungers are used when the plunger must be retracted quickly.

By rotating the lifting lever by 180°, a notch keeps the plunger in the retracted position.

The very small dimensional tolerances guarantee the necessary functional safety even in case of dirt.

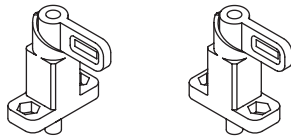
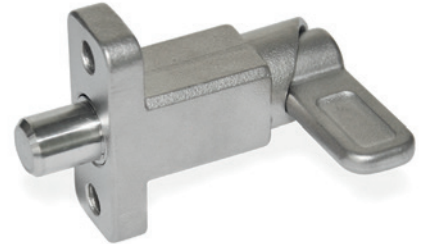
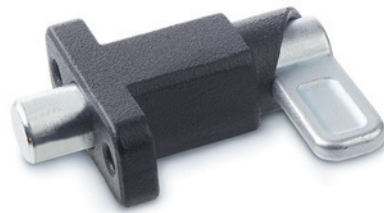

Conversion Table	
1 mm = 0.039 inch	
d1	
mm	inch
8	0.31
10	0.39
12	0.47
14	0.55
16	0.62
20	0.78

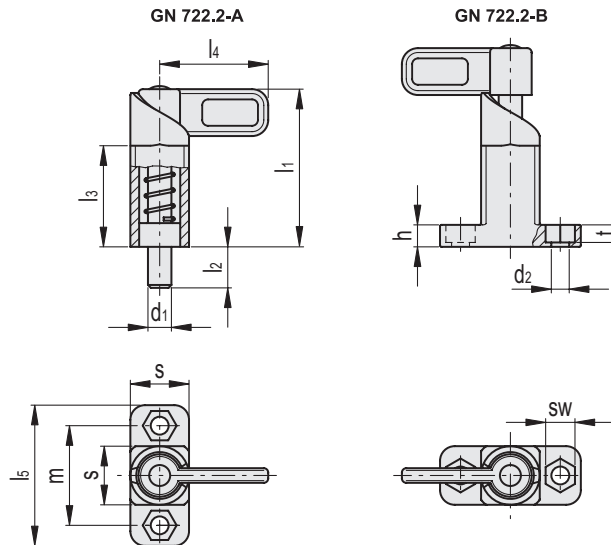

GN 722.2-A-A4

INOX STAINLESS STEEL

METRIC

Code	Description	d1		h	l1	l2	l3	l4	l5	s	sw	t	m	[N]*	[N]#	
		Plunger -0.05 -0.25	Hole +0.30 +0.10													
GN.39411	GN 722.2-8-20-A-A4	8	6.1	7.5	54	14	35	37	48	20	10	6	34	15	50	166
GN.39421	GN 722.2-10-20-A-A4	10	6.1	7.5	54	14	35	37	48	20	10	6	34	15	50	168
GN.39431	GN 722.2-12-20-A-A4	12	6.1	7.5	54	14	35	37	48	20	10	6	34	15	50	172
GN.39441	GN 722.2-14-20-A-A4	14	6.1	7.5	54	14	35	37	48	20	10	6	34	15	50	175
GN.28951	GN 722.2-16-30-A-A4	16	10.1	15	83	20	54	55	80	30	17	10	55	30	110	227
GN.28957	GN 722.2-20-30-A-A4	20	10.1	15	83	20	54	55	80	30	17	10	55	30	110	244

GN 722.2-A-SW

METRIC

Code	Description	d1		h	l1	l2	l3	l4	l5	s	sw	t	m	[N]*	[N]#	
		Plunger -0.05 -0.25	Hole +0.30 +0.10													
GN.39361	GN 722.2-8-20-A-SW	8	6.1	7.5	54	14	35	37	48	20	10	6	34	15	50	160
GN.39363	GN 722.2-10-20-A-SW	10	6.1	7.5	54	14	35	37	48	20	10	6	34	15	50	168
GN.39365	GN 722.2-12-20-A-SW	12	6.1	7.5	54	14	35	37	48	20	10	6	34	15	50	172
GN.39367	GN 722.2-14-20-A-SW	14	6.1	7.5	54	14	35	37	48	20	10	6	34	15	50	175
GN.28952	GN 722.2-16-30-A-SW	16	10.1	15	83	20	54	55	80	30	17	10	55	30	110	227
GN.28958	GN 722.2-20-30-A-SW	20	10.1	15	83	20	54	55	80	30	17	10	55	30	110	244

GN 722.2-A-ZB

Code	Description	d1		h	l1	l2	l3	l4	l5	s	sw	t	m	[N]*	[N]#	
		Plunger -0.05 -0.25	Hole +0.30 +0.10													
GN.39413	GN 722.2-8-20-A-ZB	8	6.1	7.5	54	14	35	37	48	20	10	6	34	15	50	160
GN.39423	GN 722.2-10-20-A-ZB	10	6.1	7.5	54	14	35	37	48	20	10	6	34	15	50	168
GN.39433	GN 722.2-12-20-A-ZB	12	6.1	7.5	54	14	35	37	48	20	10	6	34	15	50	172
GN.39443	GN 722.2-14-20-A-ZB	14	6.1	7.5	54	14	35	37	48	20	10	6	34	15	50	175
GN.28953	GN 722.2-16-30-A-ZB	16	10.1	15	83	20	54	55	80	30	17	10	55	30	110	227
GN.28959	GN 722.2-20-30-A-ZB	20	10.1	15	83	20	54	55	80	30	17	10	55	30	110	244

GN 722.2-B-A4

INOX STAINLESS STEEL

METRIC

Code	Description	d1		h	l1	l2	l3	l4	l5	s	sw	t	m	[N]*	[N]#	
		Plunger -0.05 -0.25	Hole +0.30 +0.10													
GN.39415	GN 722.2-8-20-B-A4	8	6.1	7.5	54	14	35	37	48	20	10	6	34	15	50	160
GN.39425	GN 722.2-10-20-B-A4	10	6.1	7.5	54	14	35	37	48	20	10	6	34	15	50	168
GN.39435	GN 722.2-12-20-B-A4	12	6.1	7.5	54	14	35	37	48	20	10	6	34	15	50	172
GN.39445	GN 722.2-14-20-B-A4	14	6.1	7.5	54	14	35	37	48	20	10	6	34	15	50	175
GN.28954	GN 722.2-16-30-B-A4	16	10.1	15	83	20	54	55	80	30	17	10	55	30	110	227
GN.28960	GN 722.2-20-30-B-A4	20	10.1	15	83	20	54	55	80	30	17	10	55	30	110	244

GN 722.2-B-SW

METRIC

Code	Description	d1		h	l1	l2	l3	l4	l5	s	sw	t	m	[N]*	[N]#	
		Plunger -0.05 -0.25	Hole +0.30 +0.10													
GN.39362	GN 722.2-8-20-B-SW	8	6.1	7.5	54	14	35	37	48	20	10	6	34	15	50	160
GN.39364	GN 722.2-10-20-B-SW	10	6.1	7.5	54	14	35	37	48	20	10	6	34	15	50	168
GN.39366	GN 722.2-12-20-B-SW	12	6.1	7.5	54	14	35	37	48	20	10	6	34	15	50	172
GN.39368	GN 722.2-14-20-B-SW	14	6.1	7.5	54	14	35	37	48	20	10	6	34	15	50	175
GN.28955	GN 722.2-16-30-B-SW	16	10.1	15	83	20	54	55	80	30	17	10	55	30	110	227
GN.28961	GN 722.2-20-30-B-SW	20	10.1	15	83	20	54	55	80	30	17	10	55	30	110	244

GN 722.2-B-ZB

Code	Description	d1		h	l1	l2	l3	l4	l5	s	sw	t	m	[N]*	[N]#	
		Plunger -0.05 -0.25	Hole +0.30 +0.10													
GN.39417	GN 722.2-8-20-B-ZB	8	6.1	7.5	54	14	35	37	48	20	10	6	34	15	50	160
GN.39427	GN 722.2-10-20-B-ZB	10	6.1	7.5	54	14	35	37	48	20	10	6	34	15	50	168
GN.39437	GN 722.2-12-20-B-ZB	12	6.1	7.5	54	14	35	37	48	20	10	6	34	15	50	172
GN.39447	GN 722.2-14-20-B-ZB	14	6.1	7.5	54	14	35	37	48	20	10	6	34	15	50	175
GN.28956	GN 722.2-16-30-B-ZB	16	10.1	15	83	20	54	55	80	30	17	10	55	30	110	227
GN.28962	GN 722.2-20-30-B-ZB	20	10.1	15	83	20	54	55	80	30	17	10	55	30	110	244

* Spring preload

Spring maximum load